

Top View

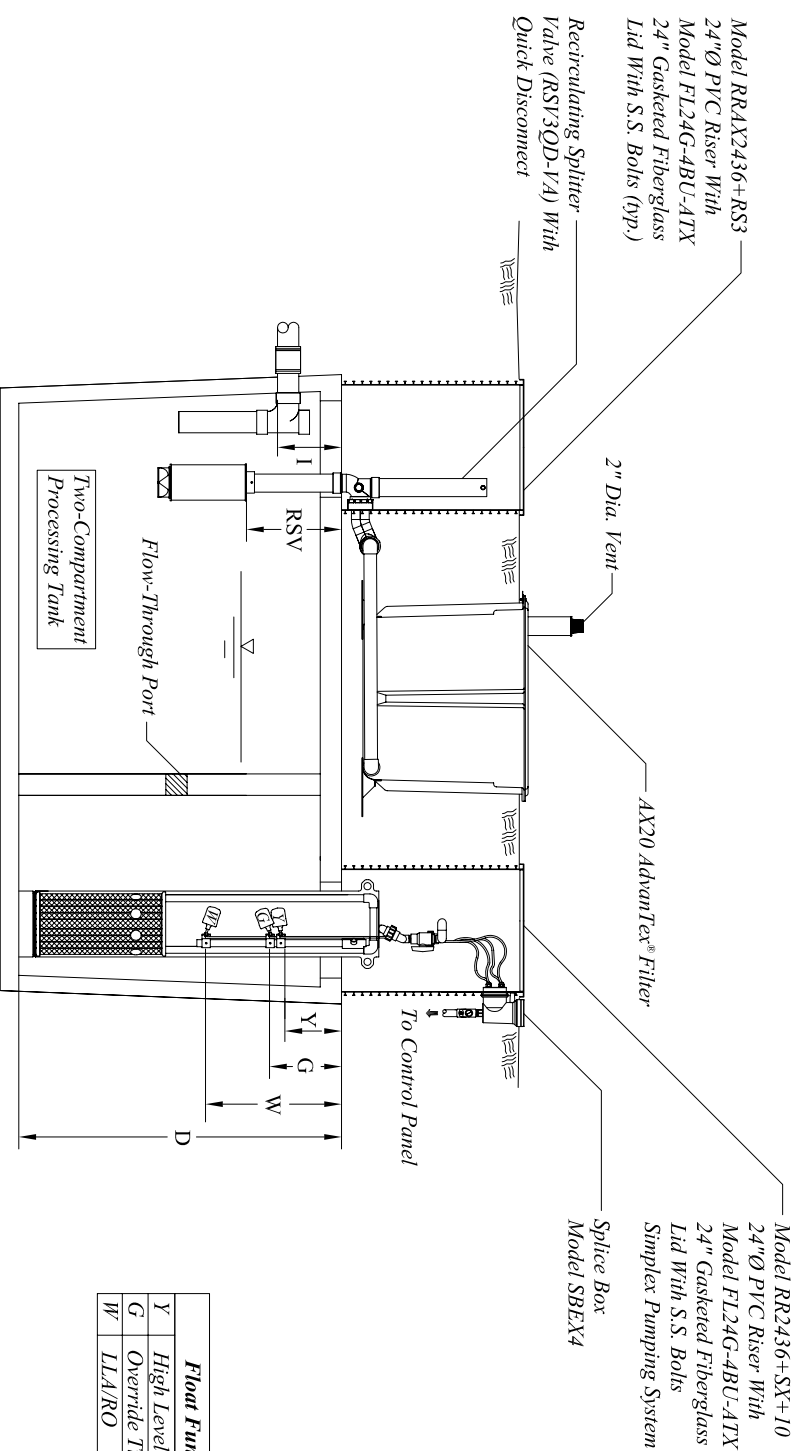

Side View

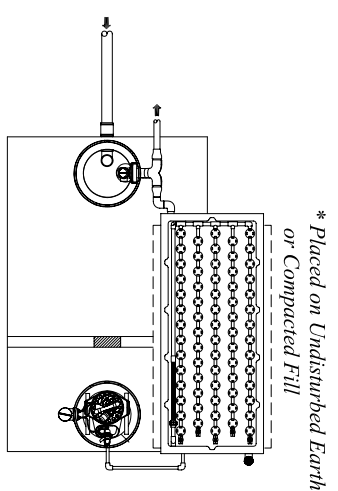

Alternate Option  
Not To Scale

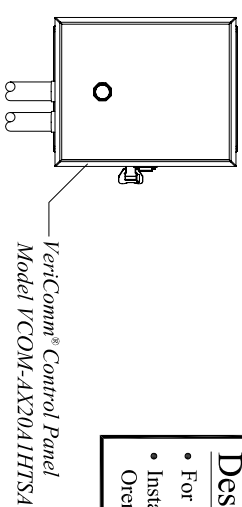

Gravity Discharge  
Control Panel Detail  
Not To Scale  
Note: For pump discharge control panel, see drawing 4 or 5 of 5.

Note: Only tanks from the manufacturers listed below shall be used.

Processing Tank Manufacturer	Tank Size	I	D	Y	G	W	RSV	Emergency Reserve
Central VA Concrete	1500 Gal.	17"	67"	17"	19"	30"	20"	390 Gallons
Winchester Building Supply	1500 Gal.	13"	74"	13"	15"	28"	18"	480 Gallons
Orenco Fiberglass Tank	1500 Gal.	11"	65"	11"	13"	26"	16"	330 Gallons
C.T. Jannison	1500 Gal.	15"	66"	15"	17"	28"	18"	480 Gallons
C.T. Jannison	2000 Gal.	10"	61"	10"	12"	23"	13"	325 Gallons
Rockingham Precast	1500 Gal.	14"	64"	14"	16"	27"	17"	450 Gallons
Allied Tank	1500 Gal.	16"	75"	16"	18"	31"	21"	570 Gallons
Hanover Precast (deep bury)	1500 Gal.	17"	76"	17"	19"	33"	23"	470 Gallons
Wrights Ready Mix	1500 Gal.	15"	65"	15"	17"	28"	18"	430 Gallons
C.S. Hines	1500 Gal.	11"	61.5"	11"	13"	25"	15"	340 Gallons
Beasley Concrete	1500 Gal.	16"	66"	16"	18"	30"	20"	455 Gallons
J & B Nixon	1500 Gal.	15"	65"	15"	17"	29"	19"	450 Gallons

Note: All tanks shall be tested for watertightness as specified on drawing 4 or 5 of 5. All concrete tanks shall have PRTA24 cast into tank for acceptance of Model RR24XX Riser.

Float Functions	
Y	High Level Alarm
G	Override Timer ON/OFF
W	LLA/RO

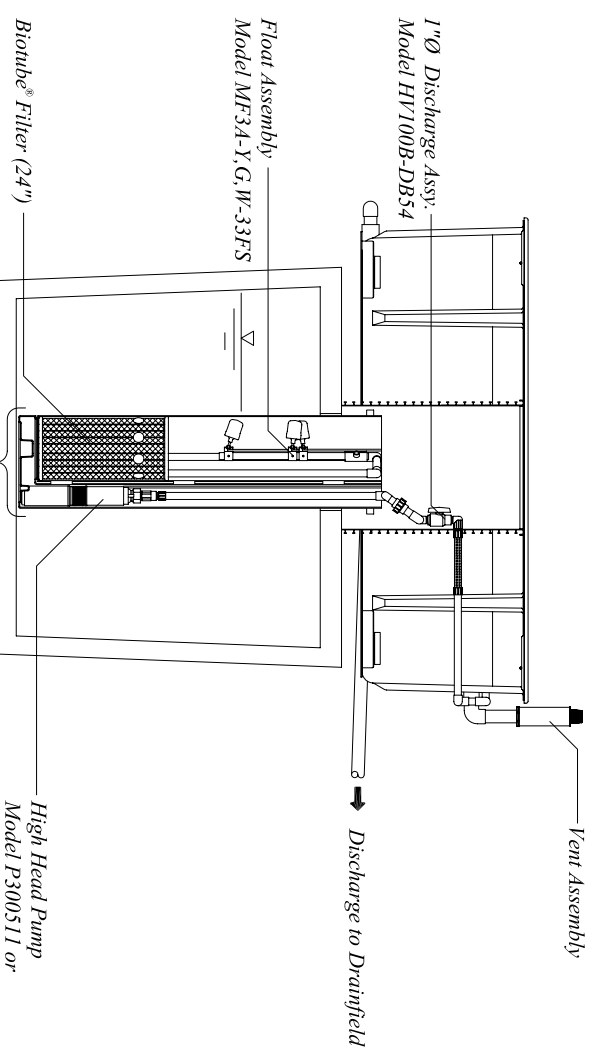

End View



Graphic Scale

**Design and Installation Notes**

- For Expected Flows Up To 4 Bedrooms
- Installation To Be Performed By An Orenco Authorized Installer Only



Orenco Systems®  
Incorporated

Title: **AdvanTex® - AX20 Virginia**

Drawing No. **NDW-ATX-VA-I**

Date: **3/03/2009**

Scale: **As Shown**

Designed By: **ENGINEERING**

Drawn By: **BEN SMITH**

Approved By: **DARREN SIMMIE**

Drawing: **1 OF 5**

Date Approved: **3/09/2009**

Revision: **A-12**